

Electrical Specifications

Type Circuit: Superheterodyne, with class "B" audio output, battery operated.

Batteries Required:

"A" supply—Philco 172R 2 volt storage battery or a dry A battery Philco Part No. 41-8011. If a dry A supply is used, a ballast lamp Philco type 1F1 must be inserted in the socket provided in the dry A battery (Part 41-8011). This small lamp acts as a voltage regulator, and maintains a constant potential of two volts on the filaments of the receiver tubes.

"BC" supply—Philco battery Part No. 41-8007 is used to supply B and C voltages. This battery contains a socket into which the receiver battery cable plug is inserted.

Current Drain: A Battery, 720 M. A.; B Battery, 20 M. A.

Philco Tubes Used: 1C7G, Detector Oscillator; 1D5G, I.F. Amplifier; 1H4G, 2nd Detector, A.V.C.; 1E5G, 1st Audio; 1H4G, Driver; 1J6G, Output.

Frequency Range: Range 1, 530-1720 K. C.; Range 2, 2.3-7.4 M. C.

Intermediate Frequency: 470 K. C.

Speaker: KR-17—B, F Cabinets; HR-12—J Cabinet.

Alignment of Compensators

To accurately adjust this receiver, precision test equipment is necessary. A signal generator such as the PHILCO MODEL 088 Signal Generator, covering from 110 to 20,000 K. C. is recommended for use in adjusting the compensators at the various frequencies specified. A visual indication of the receiver output is also necessary to obtain correct adjustment of the compensators. PHILCO MODEL 025 Circuit Tester contains a sensitive output meter and is recommended for these adjustments.

Philco Fibre Wrench No. 3164 and Fibre Handle Screw-Driver No. 27-7059 complete the necessary equipment for these adjustments. The locations of the various compensators are shown in Figs. 2 and 3.

The following procedure must be observed in adjusting the compensators:—

DIAL ADJUSTMENT—The tuning condenser is set at the maximum capacity position, by turning the tuning knob clockwise. Loosen the set screw of dial hub and set dial, with Glowing Indicator centered between the first and second index lines at the low frequency end of scale.

OUTPUT METER—The 025 Output Meter is connected between one of the plate prongs of the 1J6G tube and the chassis. Then adjust the meter to use the (0-30) volt scale.

INTERMEDIATE FREQUENCY CIRCUIT

Frequency 470 K. C.

1. Connect the 088 Signal Generator output lead through a .1 mfd. condenser, to the control grid of the 1C7G tube, and the generator ground lead to the chassis.

2. Set the range switch in position No. 1 (Broadcast), then rotate the tuning condenser of the receiver to the maximum capacity position (clockwise) and adjust the signal generator for 470 K. C. Now adjust compensators (28a) 2nd I.F. Sec., (28p) 2nd I.F. Pri., (15a) 1st I.F. Sec. and (15p) 1st I.F. Pri. for maximum output.

RADIO FREQUENCY CIRCUIT

Tuning Range 2.3 M. C. to 7.4 M. C.

1. Remove the signal generator output lead from the grid of the 1C7G tube and connect it through a 200 mmf Condenser to the antenna terminal on input panel (rear of chassis), and the generator ground lead to the ground terminal of this panel.

2. Set the range switch in position No. 2. Turn the receiver and signal generator dials to 7.0 M. C. Now adjust compensator (12) for maximum output.

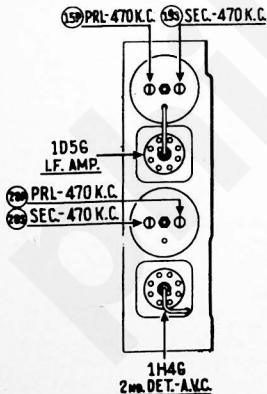

Fig. 2—I.F. Compensators Top of Chassis

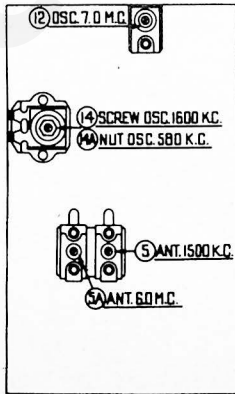

Fig. 3—R.F. Compensators Underside of Chassis

SOCKET VOLTAGES

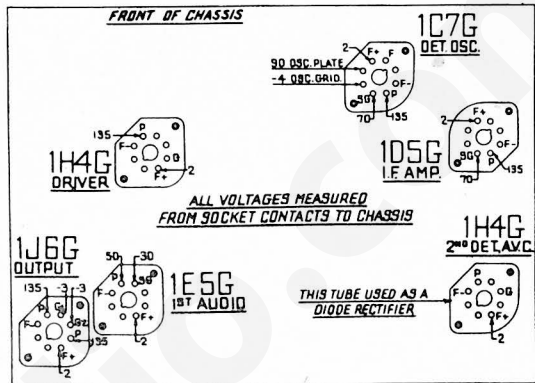

Fig. 1—Socket Voltages—Underside of Chassis View

The voltages indicated by arrows were measured with a Philco 025 Circuit Tester which contains a voltmeter having a resistance of 1000 ohms per volt. Volume Control at minimum, range switch in broadcast position.

3. Turn signal generator and receiver dials to 6.0 M. C. and adjust compensator (9a) for maximum output.

Tuning Range 530 to 1720 K. C.

1. Set range switch in position No. 1 (Broadcast). Turn signal generator and receiver dials to 1600 K. C. Then adjust (14) Osc. "Screw", and (5) antenna for maximum output.

2. Turn signal generator and receiver dials to 580 K. C. and adjust compensator (14a) Osc. "nut"—see Fig. 3—as follows: To adjust compensator (14a) the tuning condenser must be rolled for maximum output, thusly: First turn the compensator (14a) for maximum output. Then vary the tuning condenser for maximum output about 580 K. C. Now retune compensator (14a) and again vary the tuning condenser back and forth about the 580 K. C. dial mark for maximum output.

This operation of first tuning the compensator, then the tuning condenser is continued until maximum output is obtained at the 580 K. C. dial mark. If the signal generator is not accurately calibrated the maximum point on the dial of the receiver may fall slightly above or below the 580 K. C. dial mark.

3. Turn signal generator and receiver dials to 1600 K. C. and readjust compensator (14) Osc. "screw" for maximum output.

4. Turn signal generator and receiver dials to 1500 K. C. and readjust compensator (5) for maximum output.

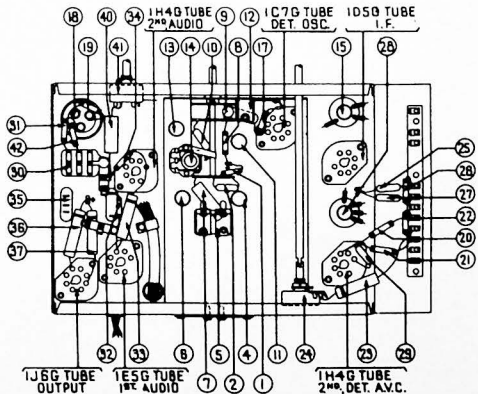

Fig. 4—View of Parts from Underside of Chassis

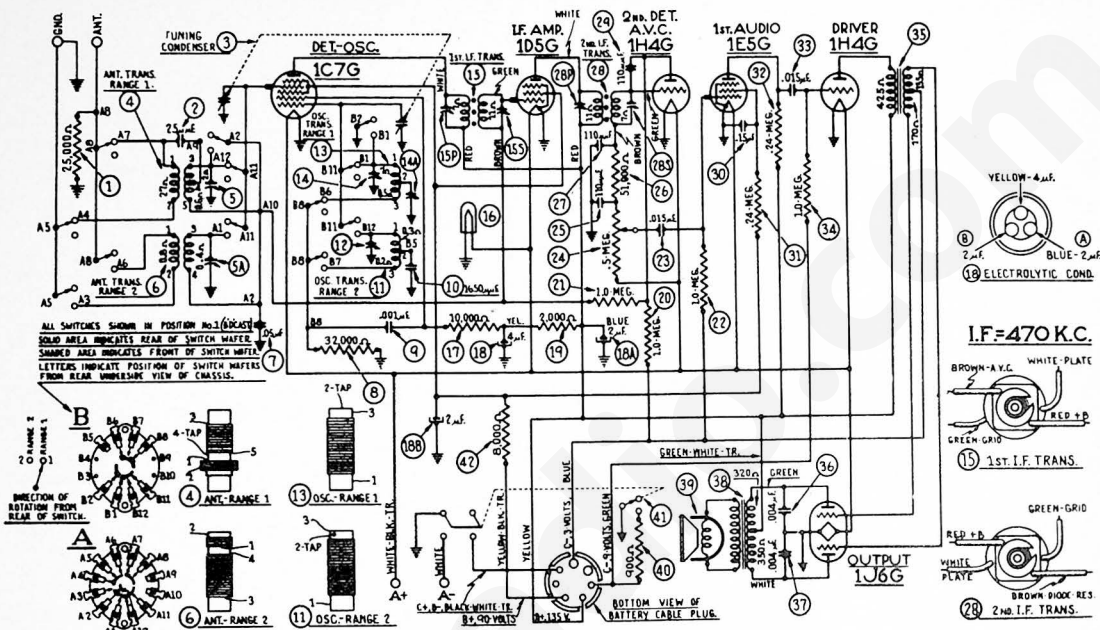

Fig. 5—Schematic Diagram—Model 37-38

Replacement Parts—Model 37-38

Schem. No.	Description	Part No.	List Price	Schem. No.	Description	Part No.	List Price	Schem. No.	Description	Part No.	List Price
1	Resistor (25,000 ohm, 1/2 watt).....	33-32539	\$0.20	26	Resistor (51,000 ohm, 1/2 watt).....	33-35139	\$0.20		Pilot Lamp.....	34-2150	
2	Condenser (28 mfd. mica).....	30-1067	.30	27	Condenser (110 mfd. mica).....	30-1031	.20		Vernier Drive.....	31-1863	.35
3	Tuning Condenser.....	31-1826	3.00	28	2d I.F. Transformer.....	32-2102	1.50		Socket—8 prog.....	27-6058	\$0.11
4	Antenna Transformer (Broadcast).....	32-2159	1.20	29	Condenser (116 mfd. bakelite).....	30-1031	.20		Socket—7 prog.....	27-6057	.11
5	Compensator (Twin).....	31-6120	.50	30	Condenser (.016 mfd. tubular).....	30-4276	.35		Tube Shield.....	28-2726	.10
6	Antenna Transformer (Police).....	32-2245	.80	31	Resistor (240,000 ohm, 1/2 watt).....	33-43439	.20		Tube Shield Base.....	28-3998	.03
7	Condenser (.06 mfd. tubular).....	30-4444	.20	32	Resistor (340,000 ohm, 1/2 watt).....	33-43439	.20		Volume Control Shaft.....	38-8058	
8	Resistor (32,000 ohm, 1/2 watt).....	33-32329	.30	33	Condenser (.016 mfd. tubular).....	30-4226	.20		Shaft Spring.....	28-4117	.40 C
9	Condenser (.001 mfd. tubular).....	30-4483	.20	34	Resistor (1 megohm, 1/2 watt).....	33-51039	.20		Shaft Retaining Clip.....	28-4394	.01
10	Condenser (1600 mmfd. semi-fixed).....	31-6096	.40	35	Audio Transformer (Interstage).....	32-7637	2.00		Mounting Grommet R.F. Unit.....	27-4317	.04
11	Oscillator Transformer (Police).....	32-3121	.40	36	Condenser (.004 mfd. tubular).....	30-4486	.30		Mounting Sleeve.....	28-2267	.01
12	Compensator (Single).....	31-6101	.20	37	Condenser (.004 mfd. tubular).....	30-4486	.30		Washer.....	W-435	.85 C
13	Oscillator Transformer (Broadcast).....	32-2120	.65	38	Output Transformer—KR17, HR12.....	32-7639	1.60		Screw.....	W-729	.45 C
14	Compensator (Twin).....	31-6100	.40	39	Cone Voice Coil—KR17.....	36-3540	.80		Washer.....	28-3921	.01
15	1st. I.F. Transformer.....	32-2100	1.50	40	Cone Voice Coil—HR12.....	36-3557	1.20		Terminal Panel (I.F. Unit).....	38-7703	.25
16	Pilot Lamp.....	34-2150	.26	41	Resistor (900 ohm, 1/2 watt).....	33-1223	.30		Spacer.....	28-4001	.25 C
17	Resistor (10,000 ohm, 1/2 watt).....	33-31039	.30	42	Power Switch.....	33-5170	1.30		Cable Assembly (Battery).....	41-3198	1.40
18	Electrolytic Condenser (4-2-3 mfd.).....	30-3183	1.40		Resistor (8,000 ohms, 1/2 watt).....	33-28039	.20		A Battery, Wet.....	172R	
19	Resistor (2,000 ohm, 1/2 watt).....	33-22039	.20		Range Switch.....	42-1195			A Battery, Dry.....	41-8011	
20	Resistor (1 megohm, 1/2 watt).....	33-51039	.20		Screen Bracket Assembly.....	31-1878	.25		B Battery.....	41-8007	
21	Resistor (1 megohm, 1/2 watt).....	33-51039	.20		Dial.....	27-5196	.45		Cable (Speaker).....	41-3207	.30
22	Resistor (1 megohm, 1/2 watt).....	33-51039	.20		Hub.....	26-7183	.10		Knob, Tuning.....	27-4321	.10
23	Condenser (.015 mfd. tubular).....	30-4356	.20		Clamp.....	26-2827	.10		Knob, Tone and Volume.....	27-4332	.10
24	Volume Control.....	33-5165	1.00		Set Screw.....	W-1506	2.00 C		Speaker, KR-17, B. and F. Cabinets.....	26-1248	10.00
25	Condenser (110 mfd. mica).....	30-1031	.20		Pilot Lamp Assembly.....	33-7875			Speaker, HR-12, J. Cabinet.....	36-1250	11.00

Figures in black type indicate circled figures in Base View.

Prices Subject to Change without Notice.